

MENZER
www.menzer-tools.com

ESM 406 Heavy Duty

Specialized in
grinding hard
substrates



MENZER ESM 406 Heavy Duty

Specialized in grinding hard substrates

The single disc machine MENZER ESM 406 Heavy Duty is particularly suitable for the preparation of very hard and demanding substrates, whether concrete, screed, stone, tiles, epoxy resin. A comprehensive range of high-quality diamond and PCD segments is available for the diamond grinding disc. The contact pressure and thus the stock removal rate can be increased by the additional weight supplied.

- ▶ For processing particularly hard and demanding substrates
- ▶ Extensive range of accessories
- ▶ Additional weight for increased contact pressure
- ▶ Durable, powerful motor
- ▶ Maintenance-free planetary gear
- ▶ Height-adjustable handle

TECHNICAL DATA

Voltage:	220-240 V ~ 50 Hz
Power:	1,200 W
Speed:	approx. 150 RPM
Motor:	Single-phase alternating current motor
Grinding plate:	Ø 406 mm
Weight of device:	32 kg

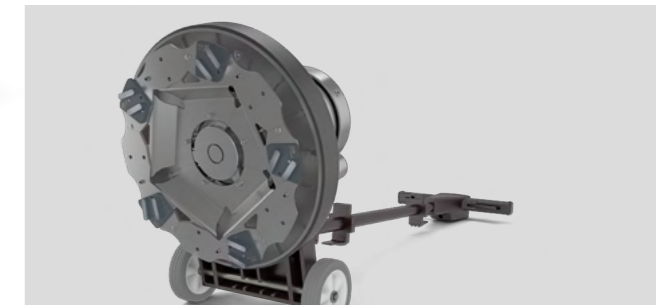

Including grinding disc for diamond segments

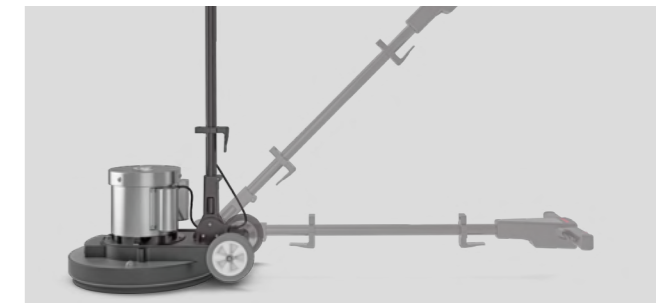

Ergonomically adjustable handle



Maintenance-free planetary gear

SCOPE OF DELIVERY

- MENZER ESM 406
- MENZER diamond grinding disc
- Additional weight: 12.5 kg